

Echelon II[®]



INDUSTRIAL ORNAMENTAL ALUMINUM FENCE

INSTITUTIONS | MUNICIPAL | PARKS & RECREATION | SCHOOLS

www.ameristarfence.com



WHY IS ECHELON II® THE MOST DOMINATE INDUSTRIAL ALUMINUM ORNAMENTAL FENCE IN THE MARKET?

UNRIVALED STRENGTH. UNMATCHED DURABILITY. UNPARALLELED AESTHETIC.



CLASSIC™

Echelon II Classic style boasts traditional extended pickets with an arrow-shaped spear. These pointed pickets act as a visual warning to potential intruders.

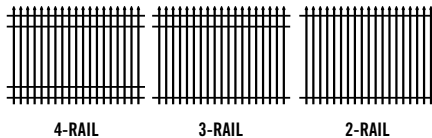

- 4-rail panels in 8', 9' & 10' heights
- 3-rail panels in 4', 5', 6' & 7' heights
- 2-rail panels in 4', 5' & 6' heights



INVINCIBLE™

Echelon II Invincible features outwardly curved pickets which serve as a warning to potential intruders. This fence style is the only industrial aluminum fence available that provides increased security with its unique "anti-climb" curved pickets.

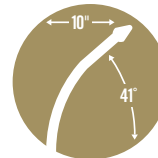
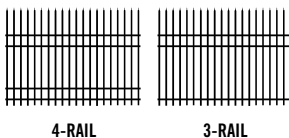

- 4-rail panels in 8', 9' & 10' heights
- 3-rail panels in 7' height

COLORS

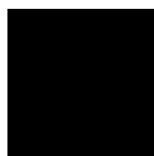

BLACK



BRONZE

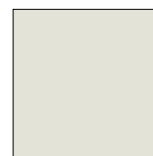

DESERT SAND

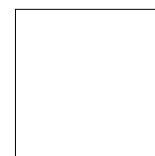

WHITE

This revolutionary fence system is comprised of aluminum posts, panels, & mounting brackets that are easily installed along any terrain. Echelon II's superior strength and durability is a result of combining top quality design components with a maintenance-free, architectural grade finish.

PICKETS	RAILS	POST OPTIONS		
1" x 1" x .062"	1.75" x 1.75" x .070"	2.5" x 2.5" x .080"	3" x 3" x .120"	4" x 4" x .250"



MAJESTIC™

Echelon II Majestic has a contemporary feel that incorporates a flush top rail which produces a stately and streamlined appearance. This fence style highlights the landscape by blending with the surrounding architectural design.

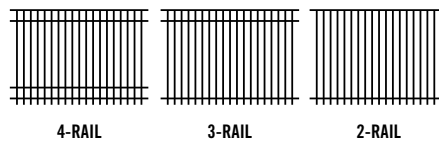

- 4-rail panels in 8', 9' & 10' heights
- 3-rail panels in 4', 5', 6' & 7' heights
- 2-rail panels in 4', 5' & 6' heights



GENESIS™

Echelon II Genesis has sleek lines of unaltered square pickets that are reminiscent of solid vertical bar wrought iron. The extended flat-topped tips can also be accented with decorative finials to enhance the fence design.

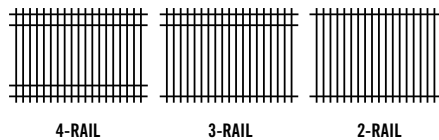

- 4-rail panels in 8', 9' & 10' heights
- 3-rail panels in 4', 5', 6' & 7' heights
- 2-rail panels in 4', 5' & 6' heights

ADORNMENTS

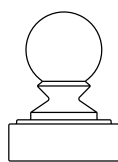

BALL CAP



RING



TRIAD



QUAD FLAIR



STRUCTURAL PARAMETERS

FORERUNNER™ (ALUMINUM) ECHELON II®

U-CHANNEL (ALUMINUM) COMPETITORS

Profile of the architectural shape of the rail.
Vertical design loads are per rail.

(For capacity of fence panel, multiply by number of rails.)

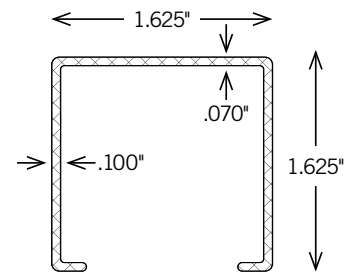
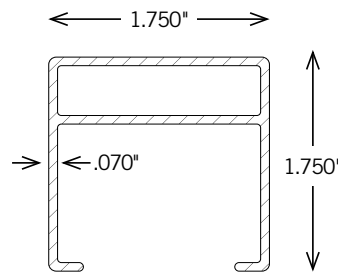

T_{EFF} = EFFECTIVE WALL THICKNESS (IN)	.070	.100 / .070
S_V = SECTION MODULUS (IN) VERTICAL	.125	.135
S_H = SECTION MODULUS (IN) HORIZONTAL	.260	.260

VERTICAL LOAD DATA PV_f = Ultimate Vertical	6' SPAN	243#	262#
	8' SPAN	182#	182#
HORIZONTAL LOAD DATA PH_f = Ultimate Horizontal	6' SPAN	505#	499#
	8' SPAN	379#	373#
VERTICAL LOAD DATA* PV_d = Vertical Design load at .66° F	6' SPAN	145#	145#
	8' SPAN	109#	109#
HORIZONTAL LOAD DATA* PH_d = Horizontal Design load at .66° F	6' SPAN	303#	299#
	8' SPAN	227#	224#

NO RIVETS. NO SCREWS. NO WELDS.

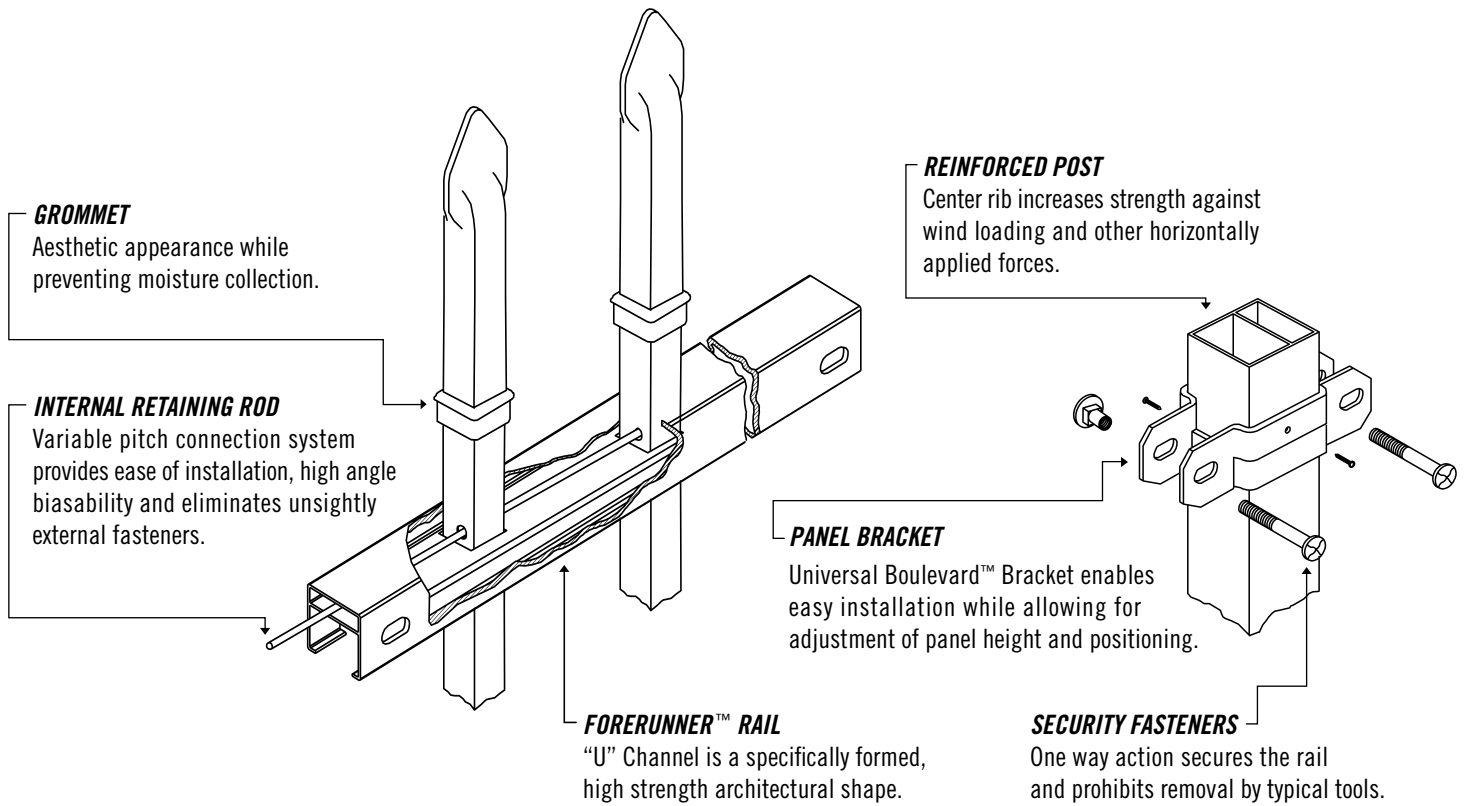

➤ INCREASED SECURITY

The ForeRunner Rail with internal retaining rod prevents the attachment from being compromised. Fasteners are not exposed.

➤ AESTHETIC DETAILS

“Good Neighbor Design” rod follows ForeRunner Centerline providing a clean and uninterrupted look void of visible screws or rivets.

➤ HIGH FUNCTIONALITY

Biasability at a minimum of 25% that requires no additional assembly.

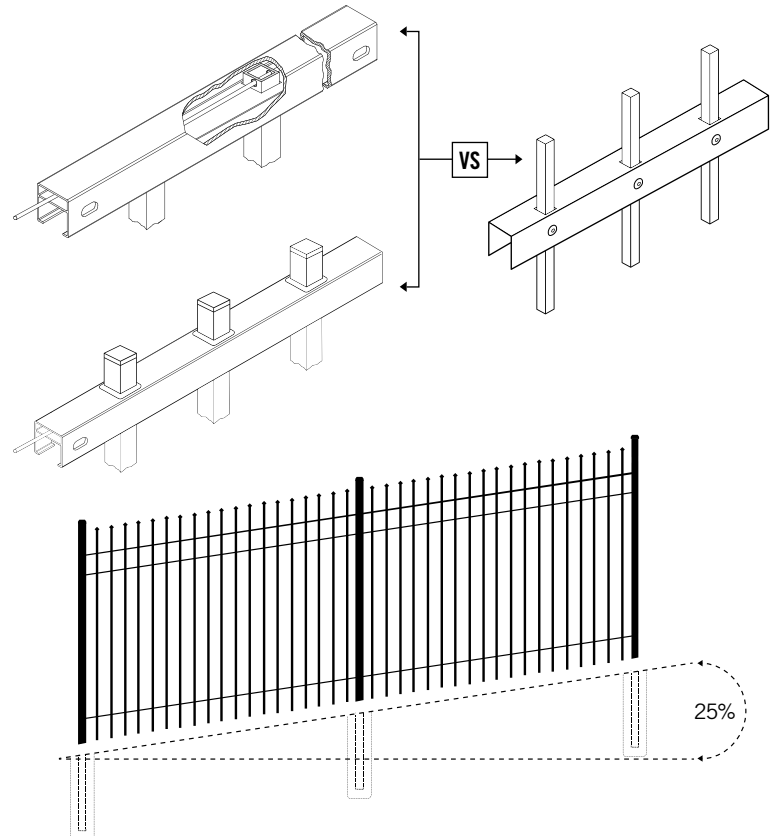

POST STRENGTH & SECURITY

There are many advantages to choosing Echelon II® reinforced posts over standard punched posts made by typical aluminum fence manufacturers.

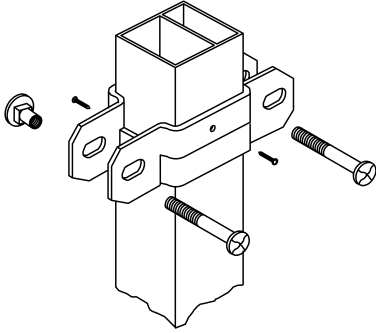

ECHELON II® POST

- Echelon II posts provide unparalleled strength due to a reinforced web profile design
- Echelon II requires a single post (*non-punched*) for all line, end, & corner posts (*one post*)
- Echelon II's wrap-around brackets are secured to the rail with a tamper proof fastener, ensuring the greatest level of security

➤ SUPERIOR FINISH

Ameristar's production facilities use a state-of-the-art polyester powder coating system that provides a durable and scratch resistant finish while emitting no hazardous volatile organic compounds. The fence components can endure over 1,000 hours of salt spray testing; proving our claim of long-lasting durability. Our industrial aluminum guarantees a maintenance-free and environmentally friendly fence.

➤ LIMITED LIFETIME WARRANTY

The Echelon family of aluminum fencing products are manufactured from superior quality materials by skilled craftsmen with the highest standards of workmanship in the industry. A six stage pre-treatment followed by an electrostatic spray of a "no-mar" TGIC polyester powder coat finish on all extruded framework provides protection against adverse environmental conditions. By using these proven techniques, Ameristar® is confident in offering Echelon with a limited lifetime warranty.

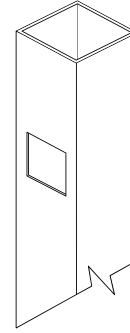

STANDARD PUNCHED POST

- Punched posts are weakened by removal of material from side-wall, yielding a vulnerable design
- Punched post designs require different posts for all line, end, & corner posts (*multiple posts*)
- Punched post systems require the rail be inserted into the post and secured using a single screw, providing no level of security





FENCE HEIGHT FEET	RAIL LENGTH FEET	FENCE POST SIZE INCHES SQUARED (SQ.)	ECHELON II® WIND LOAD CAPACITY FACTOR (PSF)	TYPICAL WIND LOAD CAPACITY FACTOR (MPH)
4'	6'	2.5" sq.	112 (PSF)	206 (MPH)
		3" sq.	213 (PSF)	285 (MPH)
	8'	2.5" sq.	84 (PSF)	178 (MPH)
		3" sq.	160 (PSF)	246 (MPH)
5'	6'	2.5" sq.	76 (PSF)	170 (MPH)
		3" sq.	145 (PSF)	235 (MPH)
	8'	2.5" sq.	57 (PSF)	147 (MPH)
		3" sq.	109 (PSF)	203 (MPH)
6'	6'	2.5" sq.	52 (PSF)	141 (MPH)
		3" sq.	99 (PSF)	194 (MPH)
	8'	2.5" sq.	40 (PSF)	123 (MPH)
		3" sq.	76 (PSF)	171 (MPH)
7'	6'	2.5" sq.	38 (PSF)	120 (MPH)
		3" sq.	73 (PSF)	166 (MPH)
	8'	2.5" sq.	28 (PSF)	104 (MPH)
		3" sq.	55 (PSF)	144 (MPH)
8'	6'	2.5" sq.	29 (PSF)	105 (MPH)
		3" sq.	56 (PSF)	145 (MPH)
	8'	2.5" sq.	22 (PSF)	91 (MPH)
		3" sq.	42 (PSF)	126 (MPH)
		4" sq.	78 (PSF)	172 (MPH)
9'	6'	4" sq.	82 (PSF)	176 (MPH)
10'	6'	4" sq.	66 (PSF)	159 (MPH)

GATE SYSTEMS

Echelon II® gate options vary from swing gates for pedestrian or vehicle entry to sliding entry gates for high functioning points of entry. Each of these gate systems are individually constructed with the highest level of craftsmanship to provide project specific performance.



**SLIDE
GATE**



**SWING
GATE**

WHY CHOOSE AMERISTAR?

➤ **KNOWLEDGE & EXPERIENCE**

Ameristar was chartered 30 years ago in response to the demand by consumers and specifiers for specialty fence products. Ameristar offers an aesthetically pleasing product that is both high in quality and affordability. This has been achieved by maximizing high-volume productivity, increasing product design strength, and promoting simplistic installation.

➤ **PROVEN CAPABILITY**

Ameristar's integrated in-house process and extensive raw material inventory results in much improved productivity and availability compared to the competition. By having a vast finished goods inventory, Ameristar is capable of delivering finished products faster than competitors who sublet the majority of their operations.

➤ **INDUSTRY LEADERSHIP**

Over the years Ameristar has continually raised the bar across the board in the manufacturing of high quality, innovative fencing products. Our demonstrated commitment to upholding higher values translates into superior products that go far beyond merely meeting minimum industry standards.



Ameristar's world headquarters, manufacturing & coil processing facilities in Tulsa, Oklahoma, USA.



LEGEND

- ★ Ameristar Headquarters
- Regional Distribution Centers



Part #9725 | Revised 08/2012

www.ameristarfence.com | 888-333-3422
1555 N. Mingo Rd. | Tulsa, Oklahoma 74116

